

## Nomor 3GPP Newsletter – March 2008

### Major decisions within 3GPP RAN

Eiko Seidel, Sujuan Feng  
Nomor Research GmbH, Munich, Germany

#### Inter-working with WiMax

Interworking with WiMAX will not be supported in Release 8

WiMAX Networking Group would like to ensure ASN standardization supports seamless Interworking with the 3GPP Release 8 EPC as part of the trusted non-3GPP accesses in 3GPP. NWG has requested 3GPP to keep the WiMAX architecture and interface details in mind as the specifications are progressed such that ASN-EPC Interworking is completed in a timely fashion. Furthermore the Service Provider Working Group (SPWG) of the WiMAX forum has standardized related requirements for session continuity, basically for providing multimedia session continuity during inter system handover to the end user. Originally the plan of the WiMAX forum was to have the specification be ready by early 2009.

After discussion in RAN plenary it was decided that RAN that the work on interworking with WiMax cannot be concluded in due time for Release 8. That means if a single mode LTE or WiMAX terminal wants to make a handover it will naturally be denied by the EPC. The next earliest time for the standardization of the interworking with WiMAX will within Release 9. If part of Release 9 the earliest time of completion will be December 2009!

Since the study item is closed now two work items were proposed to RAN plenary to standardize WiMAX - LTE and WiMAX - UMTS Mobility. The following were the supporting companies SK Telecom, KT Freetel, ETRI, Intel, InterDigital, IPWireless, Nextwave, Samsung, Sprint.

The objectives of this work item were:

- Support mobility between mobile WiMAX and LTE/UMTS systems (bidirectional) in accordance with the SA1 requirements.
- To introduce the required functionality in the LTE/UMTS specification to meet the above requirements for mobility between WiMAX and LTE/UMTS

The modification of the work items were NOT agreed in the RAN plenary.

Interworking with CDMA2000 will be supported within Release 8

Lots of progress has been made here. It seems that Qualcomm and Ericsson have been working together tightly und that the CDMA2000 and the 3GPP camp slowly converge.

The following progress was made:

- 3GPP TSG-SA has approved the TS23.402, which specifies the stage 2 architecture for providing IP connectivity using non-3GPP accesses to the Evolved 3GPP Packet Switched domain at SA#38.
- 3GPP TSG-SA WG2 considers interoperation between LTE and CDMA2000 as an essential SAE item for Release-8.
- 3GPP TSG-RAN has approved TR36.938 and the amendment to the Work Item Description for 3G Long-Term Evolution to include the scope work on network based, optimized handover between LTE and 3GPP2 technologies at RAN#38.

3GPP TSG-SA informed 3GPP2 TSG-S that 3GPP Working Groups will develop stage 3

specifications on mobility interworking between 3GPP and 3GPP2 systems to complete in Release-8 timeframe. Figure 1 shows the architecture for interworking. Optimized handover supported by this

architecture is intended for the scenario where the operator owns both the E-UTRAN access and the HRPD access, or where there is a suitable inter-operator agreement in place.

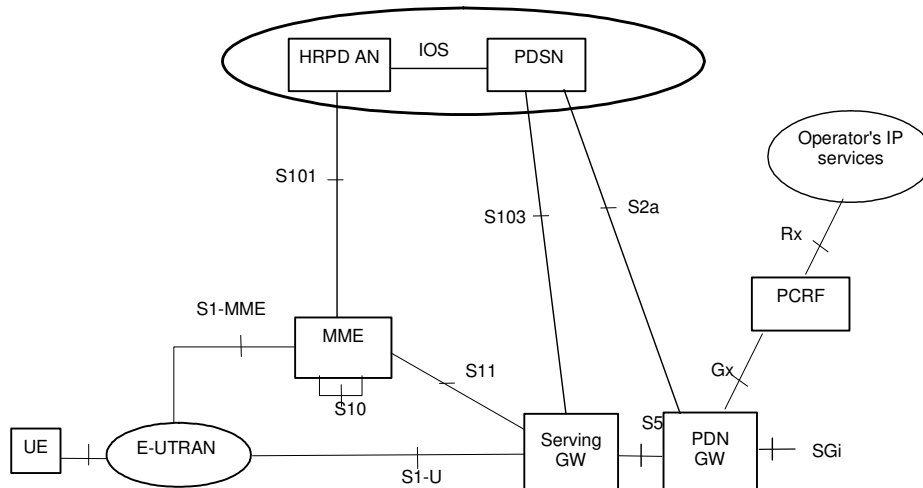

Figure 1: Architecture for optimised 3GPP-CDMA2000 HRPD handovers (non-roaming case)

### ITU-R Issues

The ITU-ad hoc needs to be tasked to elaborate the update on M.1801 and input needs to be delivered in September

### Release 8 UTRAN Work Items and Study Items

The following Work Items were closed in RAN#39:

- Further Improved Minimum Performance Requirements for HSDPA UE (FDD) - Two-Branch Interference Cancellation
- CS Voice Service over HSPA
- Performance requirements for 15 code reception with 16QAM/QPSK (FDD)
- 3G Long Term Evolution – Physical Layer
- RF/RRM Conformance Test Aspects MBMS (FDD) (Rel-6)
- Conformance test aspects – 64QAM for HSDPA (FDD)

- Conformance test aspects – Improved L2 support for high data rates
- Conformance test aspects – Multiple Input Multiple Output antennas (MIMO) for FDD
- Conformance Test Aspects - Minimum UE performance requirement for downlink physical channels in support of MTCH and MCCH operation based on type 1 enhanced receiver (Rx-Diversity)

Closed Study Items:

- Synchronised E-DCH for UTRA FDD
- HS-PDSCH serving cell change enhancements
- Long Term Evolution

### UTRA Home Node B

The Study items remains open for the RAN3 part in order to find a solution on the remaining architectural issues.

A new Work Item on the support of UTRA HNB was in principle approved and needs to be reviewed

A new Work Item for FDD Home Node B RF requirements was approved.

**Long Term Evolution**

TSG-RAN tasked all WG to review all LTE specifications in order to reduce the number of options.

The RAN1 part of the Long Term Evolution Work Item was closed. The Work Item remains open for all other WGs. The target for closure of the Work Item is June 2008.

**UE Conformance Testing**

UE Test Loop functionality is a mandatory requirement for LTE conformance testing. As it forms part of the core requirement it has a direct impact on the design of UE. Hence 3GPP RAN groups should start development of this specification as early as possible.

In case of UTRA(N), TS 34.109 defines the loopback functionality for UE conformance testing. This specification has been originally drafted by the former TSG T WG1 and approved / owned by TSG RAN WG2 to become part of the RAN specifications. It was decided that RAN5 will now assume the responsibility for the equivalent LTE version of TS 34.109

**New 3GPP RAN Study Items**

*Note: A study item will not create a specification, but will undertake a study with a technical report as outcome. Based on the outcome of the study RAN plenary might decide to create a Work Item that eventually makes modifications to current specifications or standardizes new specifications.*

**3GPP Study Item on IMT Advanced**

At RAN plenary #39 in March 3GPP approved the first study item related IMT Advanced or “4G”. The schedule is quite aligned to the ITU schedule and it is generally understood the 3GPP will very actively contribute on requirements and technology. The study item will be lead by RAN1 where the work load should, compared to other working groups, slowly decrease.

The Figure 2 illustrates the agreed time schedule for LTE Advanced. The time frame of the future 3GPP releases (Release 9, 10, 11) is not yet discussed in detail, but it could be foreseen that the study item is completed within Release 9 and the Work Item takes place in Release 10.

The study item was authored by the following companies:

Alcatel-Lucent, AT&T, CATT, China Mobile, Ericsson, ETRI, Fujitsu, Huawei, InterDigital, LG Electronics, Mitsubishi Electric, Motorola, NEC, Nokia, Nokia Siemens Networks, Nortel, NTT DoCoMo, Orange, Panasonic, Philips, Qualcomm Europe, RIM, RITT, Rohde&Schwarz, Samsung, Sharp, Telecom Italia, Telefonica, Texas Instruments, T-Mobile Intl., Toshiba, Verizon, Vodafone, ZTE

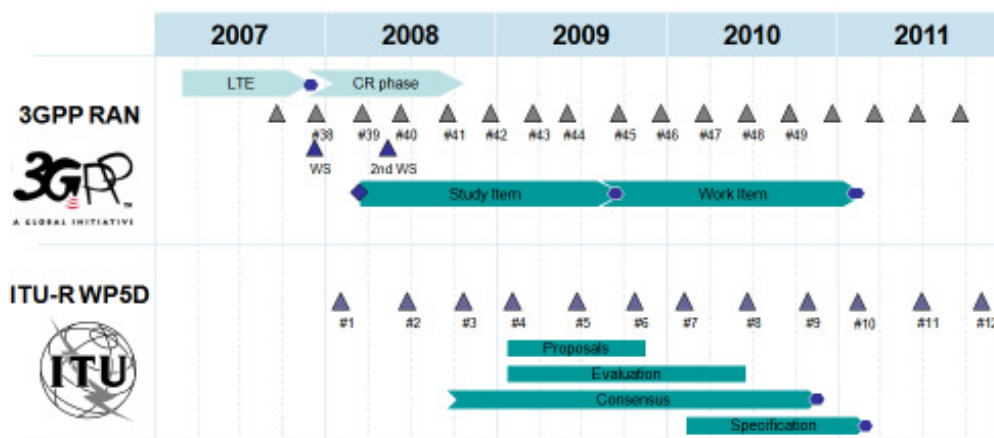

Figure 2: Agreed LTE Advanced Time Frame

The objective of the study item is:

- Define a framework for further advancements of LTE considering the time schedule of ITU-R
- Define requirements for of LTE-Advanced based on the ITU-R requirements for IMT-Advanced as well as 3GPP operators own requirements for advancing LTE considering:
  - LTE radio technology and architecture improvements;
  - Support for all radio modes of operation;
  - Interworking with legacy RATs (scenarios and performance requirements);
  - Backward compatibility of LTE-Advanced E-UTRA/E-UTRAN with E-UTRA/E-UTRAN;
  - Newly identified frequency bands and existing frequency bands.
- Identify potential solutions, technologies for the enhancements of E-UTRA (LTE-Advanced)
- To develop documents that will serve as a basis for the documentation to be submitted to ITU-R to provide the 3GPP proposals for IMT-Advanced

### 3GPP Study Item on Dual-Cell HSDPA operation

3GPP-RAN has significantly enhanced the peak user throughput as part of Release-7 (MIMO, Higher Order Modulation) and this has helped improve the average user throughput to some extent. However, there is an evident desire for even better and more consistent user experience across the cell and in particular in the outer area of the cell coverage.

The deployment of additional network resources, such as a second HSPA carrier, creates an opportunity for network resource pooling as a way to enhance the user experience, in particular when the radio conditions are such that existing techniques (e.g. MIMO) can not be used.

The study item is thus intended to assess the feasibility, benefits and complexity of combining network radio resources (i.e. cells) to address the operators' desire for enhanced user experience and enhanced user experience consistency.

The study should fulfill the following objectives:

- Evaluate the feasibility and benefits of dual cell HSDPA operation with the primary focus on the following scenario:
  - The dual cell operation only applies to downlink HS-DSCH;
  - The two cells belong to the same Node-B and are on different carriers;
  - The two cells operate with a single TX antenna;
  - The two cells operate in the same frequency band.
- Identify the enhancement to user throughput throughout the cell and in particular in the outer area of the cell coverage, considering:
  - Any UE receiver impairments caused by the implementation of dual-cell operation;
  - Node B scheduler architecture (per carrier or joint scheduler);
  - Joint Scheduler vs. per carrier scheduler coupled with load balancing.
- Identify the UE, UTRAN and system impacts of introducing downlink dual-cell operation to the existing UTRA system.
  - Impacts on implementation and complexity within the UTRA and UE;
  - Impacts on the system such as: UL control channel coverage and capacity, and operation of legacy UEs.
  - Impact to the core specifications, in particular: impact on UL and DL control channel structure Impact on L2/L3 protocols, impact on the UTRAN network interfaces and need & scope of additional UE performance requirements.

### **New 3GPP RAN Work Items**

*Note: A work item is approved if new features that are not part of other existing work items require modifications to current specifications or even require new set of specifications.*

#### **3GPP Work Item on Continuous Connectivity for packet data users for 1.28Mcps TDD**

For a high number of users in the cell it can be assumed that many users are not transmitting any user data for some time (e.g. for reading during web browsing or in between packets for periodic packet transmission such as VoIP). The corresponding overhead control channels and dedicated channels will significantly limit the number of users that can be efficiently supported.

As completely releasing dedicated channels during periods of temporary traffic inactivity would cause considerable delays for reestablishing data transmission and a corresponding bad user perception, this WI is intended to reduce the impact of control channels while maintaining the DCH state and allowing a much faster reactivation for temporarily inactive users.

Some possible solutions are discussed in the RAN1#51bis and RAN1 recommended starting a WI on CPC for 1.28Mcps TDD.

The objective of this work item is to reduce the code consumption (e.g. overhead of physical control channels or related signaling messages) of packet data users for both real-time (e.g. VoIP) and non real-time services, e.g. for users which have temporarily no data transmission in either uplink or downlink. Packet data users as considered in this work item are using only HS-DSCH/E-DCH channels without UL DPCH and DL DPCH.

The aim is to increase the number of packet data users in the UMTS 1.28Mcps TDD system that can be kept efficiently in CELL\_DCH state over a longer time period and that can restart transmission after a period of temporary inactivity with a much shorter delay (for example, <100ms) than

would be necessary for reestablishment of a new connection.

Another aim is to reduce UE power consumption in CELL\_DCH state over a long period by DTX and DRX.

Other Optimization for both real-time (e.g. VoIP) and non real-time services is not exclusive.

#### **3GPP Work Item on HSPA VoIP to WCDMA/GSM CS continuity**

A number of enhancements have been introduced in Rel-7 to optimize VoIP services over HSPA. However it is expected that when introduced, support for VoIP service would not be ubiquitous over an entire operator's network from day one. A solution should therefore exist with CS voice to provide continuity of service over an entire network. At the moment the specification does not support any such solution. This is a severe limitation that may prevent the deployment of VoIP services.

The objective of this work item is to introduce the appropriate RAN enhancements that allow VoIP to WCDMA/GSM CS continuity within the VCC framework defined in TS 23.206. Such enhancements should include:

- The RRC signalling that allows a connected mode UE to switch from a VoIP call to a WCDMA/GSM CS call
- The signalling information on network VoIP capability/preference that allows a UE to know that he has moved in/out of a VoIP-capable area
- Informing the RNC on where the VoIP call is anchored

#### **3GPP Work Item on Support of UTRA HNB**

The WID was agreed in principle, but RAN2 was tasked to review the WID.

The RAN2 study on legacy Home NB support for UTRA [R2-075466] concluded that the presently available mechanisms for legacy

mobile mobility for UTRA Home NB deployments are not optimal and hence require compromises in deployment. In the case where UTRA and LTE Home NB deployment reach dense levels the effect on RAN & CN signalling load, UE performance and finally UE battery life may become significant.

By implementing specific mobility procedures in Rel-8 mobiles to support a Closed Subscriber Group (CSG) like cell concept, it should be possible to obviate the disadvantages posed by UTRA Home NB deployments for Rel-8 mobiles. As the percentage of Rel-8 mobiles population grows, the signalling load on the network will diminish and user experience can be enhanced.

The objective of this work is to specify enhanced Rel-8 UTRA IDLE mode mobility and to consider enhancements to the ACTIVE mode mobility in order to support the CSG like cell concept (UTRA and LTE).

The work will investigate the adoption of agreed LTE CSG like concepts for UTRA. It is important that legacy mechanisms for UTRA Home NB co-exist with the concepts chosen by this WI to ensure pre-Rel-8 UTRAN UE will be supported. The WI shall not exclude the optimisation of UTRA Home NB concepts for the support of legacy terminals.

The WI will provide solutions for the following use case scenarios:

- The support of CSG (Closed Subscriber Group, or, restricted association) and of open access operations
- Minimise the impact to UEs camped on UTRA macro cells when they are in the coverage area of a non suitable UTRA Home NB
- Cell selection/reselection from UTRA macro cell to UTRA Home NB
- Cell selection/reselection from UTRA Home NB to UTRA
- Cell selection/reselection of UEs between UTRA Home NBs

- Handover of ACTIVE UE from UTRA Home NB to UTRA macro cell

The WI should consider solutions for the following use case scenarios:

- The support of semi-open access operation (or signalling association) where a UE can exchange signalling and limited data on non suitable UTRA Home NB
- Minimise impact on UEs camped on LTE/GERAN macro cells when they are in the coverage area of a non suitable UTRA Home NB
- Cell selection/reselection from LTE macro cell to UTRA Home NB
- Cell selection/reselection from UTRA Home NB to GERAN/LTE
- Handover of ACTIVE UE from macro UTRA/LTE cell to UTRA CSG Home NB in coverage of UTRA Home NB
- Handover of ACTIVE UE from UTRA Home NB to GERAN/LTE macro cell
- Handover of ACTIVE UE between UTRA Home NB
- Handover of ACTIVE UE from macro LTE cell to UTRA hNB in coverage of UTRA hNB

### 3GPP Work Item on FDD Home NodeB RF requirements

UTRAN is not optimally suited for Home NodeBs application as UTRAN was developed and defined under the assumption of coordinated network deployment whereas home NodeBs are typically associated with uncoordinated and large scale deployment.

Aim of this work item is to amend the UTRAN NodeB related RF specifications as suggested in the RAN4 specific part of TR 25.820 to support the Home NodeBs application. No changes to the UE RF specifications are foreseen.

The scope of this work item is limited to the UTRA FDD mode.

The objectives of this WID include:

- Update the radio performance requirement specification TS 25.104 as suggested by TR

25.820, in particular, the work shall cover but shall not be limited by the following:

Where square bracketed values are suggested in 3GPP TR 25.820, to conduct further work as required to agree appropriate values;

Where it is suggested that performance values in 3GPP TS 25.104 may be subject to change to conduct further work as required to see if this is necessary.

Furthermore, the test specification TS 25.141 would need to be updated accordingly.

It is foreseen that the HNB-specific additions to TS 25.104 / 25.141 can be accommodated in a manner similar to the already existing BS classes.

- Ensure that operators have the ability to achieve control of HNB power; in particular, the work should cover but shall not be limited by the following,

The operator has the means to obtain measurements of the strength of signals and the identity (to allow macro neighbour cell list building) from the macro cell layer and from other HNBs. Measurements may be made by the HNB or may make use of existing measurements defined for the UE; no new UE measurements will be defined.

The operator has the means to set the maximum output power of the HNB, this is expected to introduce changes to TS 25.104. Square bracketed values are suggested in 3GPP TR 25.820, further work will be conducted as required to agree appropriate values.

The operator has guidance on how to control HNB power and expected performance levels in the relevant scenarios, work will be conducted to investigate if the same mechanism may be used to for controlling HNB power versus the macro cell layer and versus other HNB. Additionally, similar mechanisms may be applied to control HNB coverage in the case of open access HNB, an issue that was not explored in the Study

Item. A TR in the 900 series will be created in order to capture this guidance.

### 3GPP Work Item on HS-DSCH Serving Cell Change Enhancements

A study item has been started at RAN#38 to review the reliability of the HS-DSCH serving cell change procedure in the context of real time services and considering the latest HS-DSCH related features and field experience.

The study item HS-PDSCH serving cell change enhancements, has concluded that the success rate of the serving cell change procedure is compromised in some difficult scenarios and that enhancements of the serving cell change procedure would make sense to help improve success rate in difficult scenarios.

Candidate schemes for enhancement techniques have been presented and initially discussed in RAN WG1 and RAN WG2. These techniques are mostly related to procedures defined under RAN WG2's responsibility. It would make sense to continue further work on enhancement techniques in form of a work item under RAN WG2's lead.

The work item should aim at identifying and specifying necessary enhancements to the HS-DSCH serving cell change procedure, focusing on necessary modifications to the:

- Radio protocol procedures and structures
- lub/lur protocols
- UE, Basestation and RRM performance requirements

The amount of options as well as the impact on UE and network implementations should be minimized.

### 3GPP Work Item on Conformance Test Aspects - Network Selection Enhancements

The core specifications for Release 7 have been updated for network selection enhancements and the associated conformance test specifications need to be produced.

CT approved their corresponding work item in meeting #32 in Warsaw, Poland. Document CP-060357 describes that the following areas were to be covered by the CT WI:

- Enhancements to procedure to select the last registered PLMN
- Time to select a network at power on
- HPLMN control of selected VPLMN
- Mitigation of problem of accidental roaming in border areas
- PLMN selector list implementation in the UE
- Various improvements to manual selection procedures
- Enhancements to EHPLMN
- Enhancements to REFRESH command
- Consider introduction of new RATs in the PLMN selector lists.

The supporting companies have analyzed the CRs and are planning to provide test cases for the following areas in RAN5:

- Presentation of additional information in Manual Mode
- Steering of Roaming
- Displaying EHPLMNs in manual mode
- Last RPLMN
- Network selection mode at switch-on
- Exception in manual network selection mode when HPLMN is available at power-on

#### 3GPP Work Item on Conformance Test Aspects - MBSFN for HCR and VHCR TDD

The core specifications for Release 7 have been enhanced by introduction of the MBSFN feature and the performance requirements for MBMS (TDD) have been specified. Test specifications need to be updated accordingly. This work item will enable the conformance testing of MBSFN for HCR and VHCR TDD.

The technical objective of this work item is to provide for conformance testing of the MBSFN feature covering the signalling Layer 2 and 3 aspects, RF characteristics and Radio Resources Management aspects.

#### 3GPP Work Item on Conformance Test Aspects - CS Voice Service over HSPA

The core specifications for Rel-8 have been enhanced by introduction of CS Voice Service over HSPA feature and the test specifications need to be updated accordingly. This work item enables the conformance testing of CsHspa

The technical objective of this work item is to provide for conformance test specifications covering the CS Voice Service over HSPA feature.

**Disclaimer:** This information, partly obtained from official 3GPP meeting reports, is assumed to be reliable, but does not necessarily reflect the view of Nomor Research GmbH. This report is provided for informational purpose only. We do not accept any responsibility for the content of this newsletter. Nomor Research GmbH has no obligation to update, modify or amend or to otherwise notify the reader thereof in the event that any matter stated herein, or any opinion, projection, forecast or estimate set forth herein, changes or subsequently becomes inaccurate.