

Updates in 3GPP RAN standardisation

Eiko Seidel, Chief Technical Officer
Nomor Research GmbH, Munich, Germany
July 2008

Release 8 handling

SA Plenary was revising the features that should be part of release 8 or should be excluded. The following decisions are made:

The following features are to be retained within the Release 8 work:

- Single Radio Voice Call Continuity for 3GPP
- SAE for generic support for non-3GPP accesses
- SAE impacts on IMS
- CS fallback

The following features are to be removed from the Release 8 work:

- SAE aspects of Emergency Calls (both GPRS and LTE)
- Functions and procedures for SAE to support LTE MBMS
- Functions and procedures for SAE to support Control Plane Location Based Services
- Circuit Switched voice over EPS
- Single Radio Aspects of SAE for Optimised Handover with WiMAX

In addition TSG SA has agreed that any of the above features that do not become part of Release 8 will be considered as candidates for early completion (target date December 2009). Note this does not make any assumption about the Release 9 completion date.

According to SA Plenary decision same features such as MBMS related part will be removed from current specifications! For some features "forward compatibility" will need to be ensured to ease the introduction at a later state. For

instance Rel.8 UEs should be able to operate on mixed carrier (multicast/unicast) in Rel.9 networks by ignoring MBMS subframes. Similarly a Rel.8 UE should ignore a Rel.9 dedicated carrier and not log onto it. Therefore MBMS specific signalling must already be supported by Rel.8.

Handling lack of interoperability testing of mandatory LTE features

There is a high likelihood that conformance tests as standardized within RAN5 will not be available for all features when the first LTE UEs are release into the market. That means that proper testing is mandatory features is not available during the time of the initial LTE network deployments.

The features were divided into three different categories:

- High: Features expected to be used for the initial devices to be deployed in 2010.
- Medium: Features which will not be used for the initial deployment, but there is a possibility that these will be used in the future, e.g. 2 or 3 years later from the initial deployment.
- Low: Features for which test cases will be addressed in RAN5 after the completion of the High and Medium priority test cases.

As per the NGMN operator proposal, medium and low priority features will not be part of the initial LTE deployments.

The handling of these features is currently being discussed. Possible options are:

1. Introduce a UE capability parameter for each of the each low priority features. The feature becomes optional for the UE to support but it enables UEs to indicate to the network that they support a feature only after both conformance testing and IOT have been successfully conducted. As a variant of this approach it might be possible to group some related feature and introduce a single capability parameter to indicate support for the whole group.
2. Introduce a 'Support for feature' indicator for each feature for which testing is not initially available. In principle the feature remains mandatory within the specification but the indicator enables the UE to inform the network when conformance testing and IOT have been successfully conducted. In a later release it would be possible to mandate the UE to indicate that the feature is supported.
3. Delay the feature to release 9.
4. Remove the feature from the specification.

Therefore all the working groups will review the LTE feature priority/test lists. It is expected that as a minimum for all features, or group of features, there would need to be some signalling indication between UE and eNode B such that there is an understanding of whether the UE is supporting the feature.

In conclusion in the current situation there are mandatory features that will not be covered by conformance testing nor be available for IOT at the time that LTE UEs start to ship. This presents an unacceptable level of risk of interoperability problem if the feature is later enabled by the network and time should be spend to come up with solving this problem.

Status current Work and Study Items

The following Work Items and Study Items were completed at RAN#40:

Work Items:

- UMTS in 700MHz band (FDD)
- Improved L2 for uplink

Testing Work Items:

- Conformance Test Aspects – 16QAM for HSUPA (FDD)
- Conformance Test Aspects – Continuous connectivity for packet data users

Study Items:

- Home NodeB/eNodeB study item
- Scope of future HSPA Evolution for 1.28Mcps TDD study item

New Work Items

MIMO for 1.28 Mcps TDD

WID in RP-080485

Support by: CATT, RITT, Spreadtrum Communications, TD-TECH, ZTE

The purpose of this work item is to improve system capacity and spectral efficiency by increasing the data throughput in the downlink within the existing carrier. This will be achieved by means of deploying multiple antennas at both UE and Node B side.

Support for Additional Navigation Satellite Systems (ANSS) for LCS

WID in RP-080346

Support by: Qualcomm Europe, AT&T, Spirent, TeleCommunications Systems

The objective of this work item is to include support for Additional Navigation Satellite Systems (ANSS) to UTRAN specifications by defining new GANSS IDs for the following navigation satellite systems:

- Modernized GPS;
- SBAS (Satellite Based Augmentation Systems; limited to EGNOS, WAAS, GAGAN, MSAS);
- QZSS (Quasi Zenith Satellite System);
- GLONASS.

Extensions to existing GANSS assistance data elements where required shall allow to natively support these additional navigation satellite systems (and their hybrid use) using UTRAN signalling.

Dual-Cell HSDPA operation on adjacent carriers

WID in RP-080490

Support by: Ericsson, Qualcomm Europe, Huawei, 3, TeliaSonera, Orange, Bouygues Telecom, eMobile Softbank Mobile, Telefonica, Vodafone

The deployment of additional network resources, such as a second HSPA carrier, creates an opportunity for network resource pooling as a way to enhance the user experience, in particular when the radio conditions are such that existing techniques (e.g. MIMO) cannot be used. The study item on Dual-Cell HSDPA operation has assessed the feasibility, benefits and complexity of combining network radio resources (i.e. cells on adjacent carriers).

The work item should fulfill the following objectives:

- Specify dual-cell HSDPA operation for the following scenario:
 - The dual cell transmission only applies to HSDPA physical channels
 - The two cells belong to the same Node-B and are on adjacent carriers
 - The two cells do not use MIMO to serve UEs configured for dual cell operation
 - The two cells operate in the same frequency band
- Introduce the functionality for the relevant specifications of
 - UL and DL control channel structure
 - L2/L3 protocols
 - UTRAN network interfaces
 - UE RF and performance requirements

The work items was opposed by 8 companies, but eventually approved after controversial discussion.

UTRAN Architecture for 3G HNB

WID RP-080487

Support by Alcatel-Lucent, Kineto, Nokia Siemens Networks, Nokia, Huawei, Telefonica, NEC, Motorola, TeliaSonera, Samsung, Vodafone, TIM, T-Mobile, AT&T

The 3G Home Node B study item was closed and a work item for UTRAN Architecture for 3G HNB was approved. It was also concluded that new functions such as the HNB Registration and UE Registration would be supported via the new protocol Home NodeB Application Protocol (HNBAP) between the 3G HNB and HNB-GW. RAN4 is likely to define a new BS class for Home Node Bs.

The objective of this work is to

- specify an architecture for 3G HNB access, comprising
 - a reference network architecture
 - an exhaustive list of new HNB specific functions together with the definition of the functional split between the 3G HNB and the 3G HNB-GW.
- define and specify the Iuh interface between the 3G HNB and the 3G HNB-GW comprising
 - the signalling transport with the aim to reduce the number of alternatives considered for the signalling transport protocol stack at the Iuh interface as shown in **Fehler! Verweisquelle konnte nicht gefunden werden.**

- the user data transport- the C-plane functions (e.g. HNB Registration and UE Registration).
- study further and specify, if needed, the HNB-GW Discovery procedure
- study further and specify the impacts of the HNB (auto)-configuration aspects on the UTRAN signalling.

Figure1 describes the newly defined architecture of the home Node B with the Iuh that is going to be standardized.

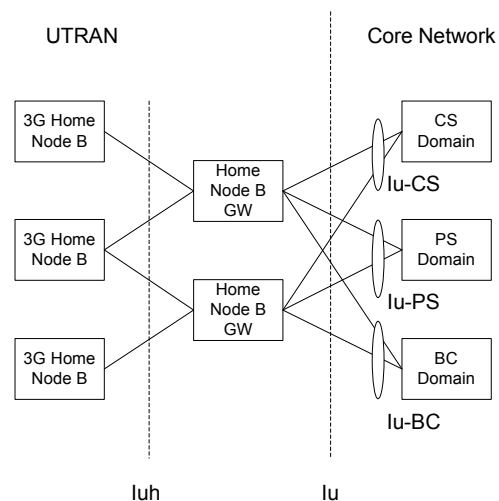

Figure 1: Home Node B interface architecture according to TS25.820

Conformance Test Aspects – Improved L2 for uplink

WID in RP-080310

The technical objective of this work item is to provide for conformance test specifications covering the Improved L2 for uplink enhancements introduced in Rel-8. The scope of the work item covers protocol testing.

Conformance Test Aspects – Performance requirements for 15 code reception with 16QAM/QPSK

WID in RP-080311

The technical objective of this work item is to provide for conformance test specifications covering the Rel-8 performance requirements for 15 code reception with 16QAM/QPSK. The scope of the work item covers RF testing.

UE conformance test aspects – MBMS LCR TDD Physical Layer Enhancement

WID in RP-080318

The technical objective of this work item is to provide for conformance testing of the MBMS LCR TDD Physical Layer Enhancements feature covering the RF characteristics, Radio Resource Management and Signalling.

Conformance Test Aspects – 64QAM for 1.28Mcps TDD HSDP
WID in RP-080334

The technical objective of this work item is to provide for conformance test specifications covering the 64QAM for 1.28Mcps TDD HSDPA feature introduced in Rel-8. The scope of the work item covers both protocol and RF testing.

Conformance Test Aspects – MBSFN for FDD
WID in RP-080336

The technical objective of this work item is to provide for conformance test specifications covering the MBMS FDD physical layer enhancements feature introduced in Rel-7. The scope of the work item covers both protocol and RF testing.

New Study Items

No new study items were approved

Note: This newsletter is provided to you by Nomor Research GmbH. Similar documents can be obtained from www.nomor.de. Feel free to forward this issue in electronic format. Please contact us in case you are interested in collaboration on related subjects.

Disclaimer: This information, partly obtained from official 3GPP meeting reports, is assumed to be reliable, but do not necessarily reflects the view of Nomor Research GmbH. The report is provided for informational purpose only. We do not accept any responsibility for the content of this newsletter. Nomor Research GmbH has no obligation to update, modify or amend or to otherwise notify the reader thereof in the event that any matter stated herein, or any opinion, projection, forecast or estimate set forth herein, changes or subsequently becomes inaccurate.