

Nomor 3GPP Newsletter – June 2007

Overview LTE PHY: Part 1 – Principles and numerology etc

Authors: Eiko Seidel

LTE Frame Structure

Duplex schemes

- TDD and FDD are supported
- ** newsletter only treats FDD in the following **

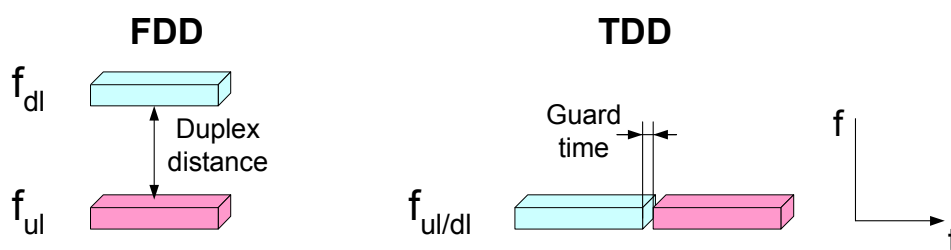

Figure 1: Time and Frequency Division Duplex

- Goal is to maximize commonality, but some inherent differences such as guard period, time advance, channel reciprocity etc will be existing

Frame structure

- Same frame structure for uplink and downlink and TDD and FDD

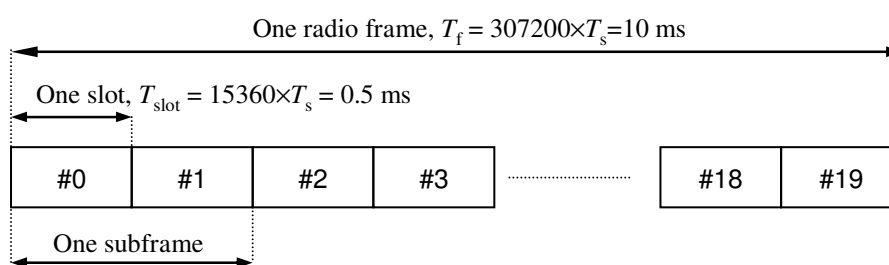

Figure 2: LTE Frame Structure (Type 1)

- A second frame structure (Type 2) is defined for co-existence with 1.28 Mcps UTRA TDD (TD-SCDMA) ** not treated in this news letter in the following **

Slot Structure

- Slot consist of 7 symbols, separated by the OFDM cyclic prefix
- Different CP length only since is can not be evenly divided by 7 symbols

Nomor 3GPP Newsletter – June 2007

Overview LTE PHY: Part 1 – Principles and numerology etc

Authors: Eiko Seidel

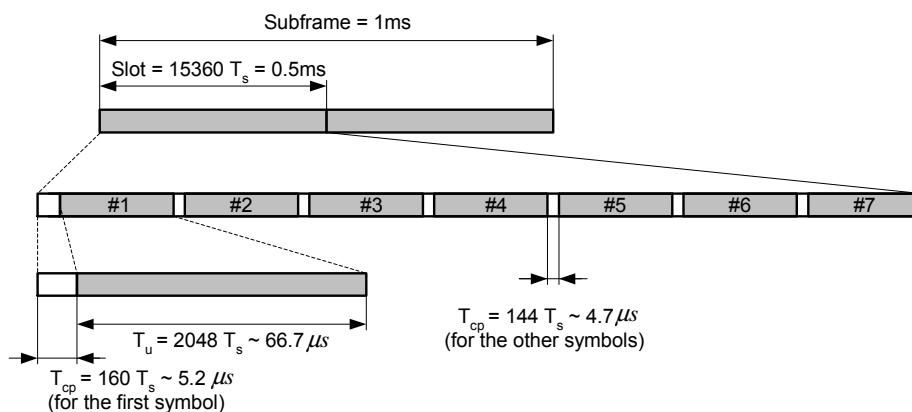

Figure 3: Slot structure for short cyclic prefix

- Also long CP with only 6 Symbols is existing for very large cells or MBSFN transmission

LTE Numerology

- Flexible bandwidth allocation supported by OFDM
- Still different RF filter will be required
- Frame structure always the same
- Sampling frequency is an transmitter and receiver implementation issue
- Sampling rate is multiple of 3.84 MHz \pm single clock for multi-mode UE with WCDMA
- Smallest bandwidth that is supported was modified recently and needs to be updated

Table 1: Overview of LTE Numerology

Spectrum Allocation	xxx MHz	2.5 MHz	5 MHz	10 MHz	15 MHz	20 MHz
Frame Duration	$T_{\text{frame}} = 10 \text{ ms}$					
Subframe Duration	$T_{\text{subframe}} = 1 \text{ ms}$					
Slot Duration	$T_{\text{slot}} = 0.5 \text{ ms}$					
Symbol Duration	$T_u \sim 66.7 \mu\text{s}$					
Subcarrier Spacing	$\Delta f = 15 \text{ kHz}$					
Sampling Frequency f_s	xxx MHz	3.84 MHz	7.68 MHz	15.36 MHz	23.04 MHz	30.72 MHz
FFT Size	xxx	256	512	1024	1536	2048
Number of Subcarrier	xx	150	300	600	900	1200
RB per subframe	x	12	25	50	75	100
Symbole per subframe	Short CP $N_{\text{sym}} = 7$			Long CP $N_{\text{sym}} = 6$		
CP Length (short CP)	$T_{\text{cp}} = 5.21 \mu\text{s}$ for Symbol 0 $T_{\text{cp}} = 4.69 \mu\text{s}$ for Symbol 1-6			$T_{\text{cp-e}} = 16.7 \mu\text{s}$ for all symbols		

Nomor 3GPP Newsletter – June 2007

Overview LTE PHY: Part 1 – Principles and numerology etc

Authors: Eiko Seidel

Sub-carrier spacing:

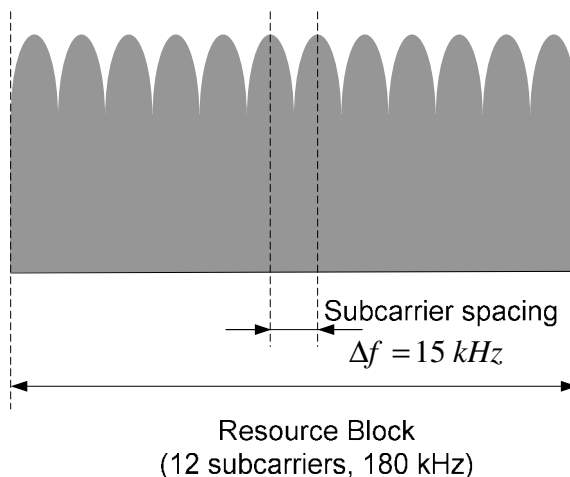

- Reduced subcarrier spacing of 7.5 KHz for MBSFN operation also supported
- Center subcarrier (DC subcarrier) not used to allow for direct conversion receiver implementation

LTE Resource Blocks

LTE supports localized OFDM where adjacent symbols and sub carrier are scheduled. Resources are grouped into two dimensional Resources Blocks. A Resource Block (RB) is the minimum unit a scheduler can allocate.

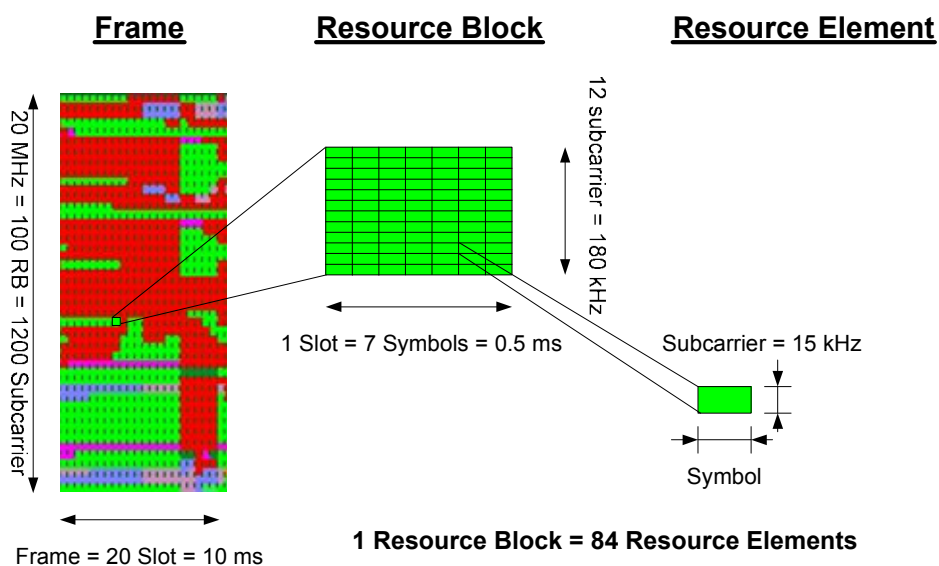

Figure 4: Illustration of frame structure, resource block and resource element

Nomor 3GPP Newsletter – June 2007

Overview LTE PHY: Part 1 – Principles and numerology etc

Authors: Eiko Seidel

- One symbol of one subcarrier is called Resource Element

MIMO Resource Allocation

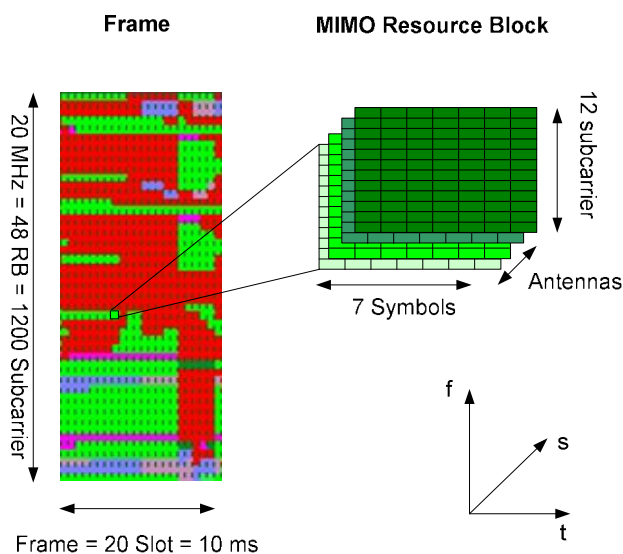

Figure 5: Illustration of MIMO frame structure, resource block and resource element

- MIMO – Tree dimensional resource block (Time, Frequency, Space)
- Spatial component defined by antenna port p ($p \in 0, 1, 2, 3$) (defined by the reference signal)
- p allocated to one user SDM - Space Division Multiplexing
 - multiple streams to one user also called Single User MIMO
 - theoretically double peak data rate for two streams on two transmit antennas
 - only supported in the downlink, uplink would be too complex
- p allocated to multiple users SDMA – Space Division Multiple Access
 - multiple streams to different user also called Multi User MIMO MU-MIMO
 - Baseline method for uplink
 - Two user can transmit on the same resource block
 - Use of mutually orthogonal pattern
 - Only single transmit antenna required
 - Rx Diversity still possible at Node B
- Semi static switching between SU-MIMO and MU-MIMO

Nomor 3GPP Newsletter – June 2007

Overview LTE PHY: Part 1 – Principles and numerology etc

Authors: Eiko Seidel

LTE Physical Layer Processing for shared channels

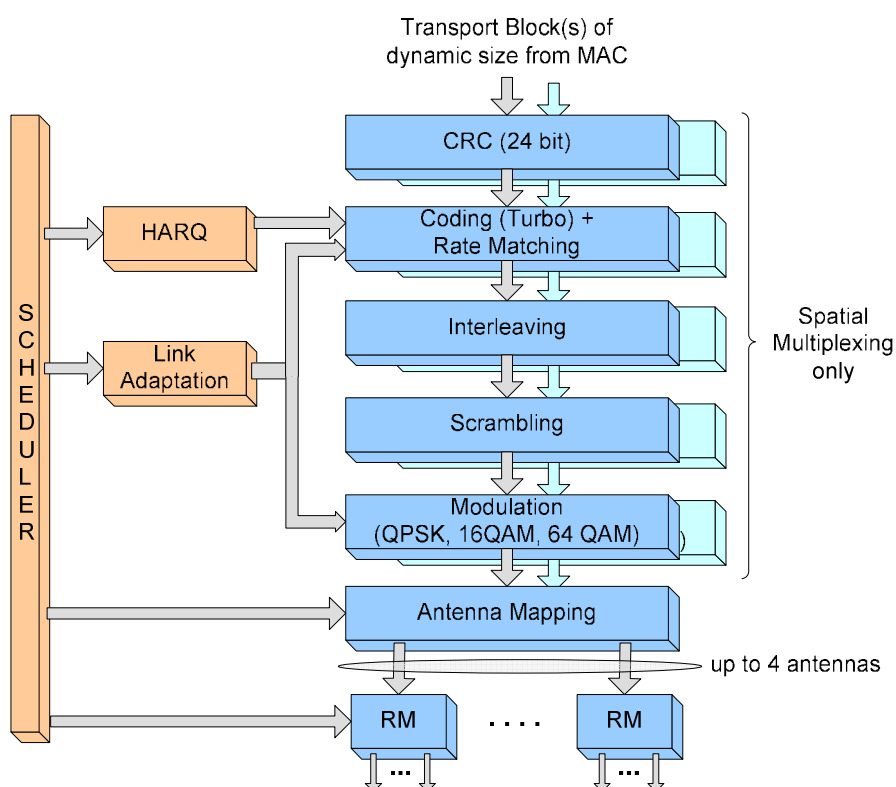

Figure 6: Overview of LTE Physical Layer Processing for shared channels

- One Transport Block per slot or two Transport Blocks in case of spatial multiplexing
- MIMO and multiple transmit antennas only supported in the downlink
- CRC check with fixed size of 24 Bit

Channel coding

- Same encoding principles are used as in UMTS
- Maximum code block size = 6144 bit
- Turbo Interleaver replaced by QPP interleaver (Quadrature Permutation Polynomial). QPP has been selected to parallelizing the encoding, reduce complexity for very high data rates

Nomor 3GPP Newsletter – June 2007

Overview LTE PHY: Part 1 – Principles and numerology etc

Authors: Eiko Seidel

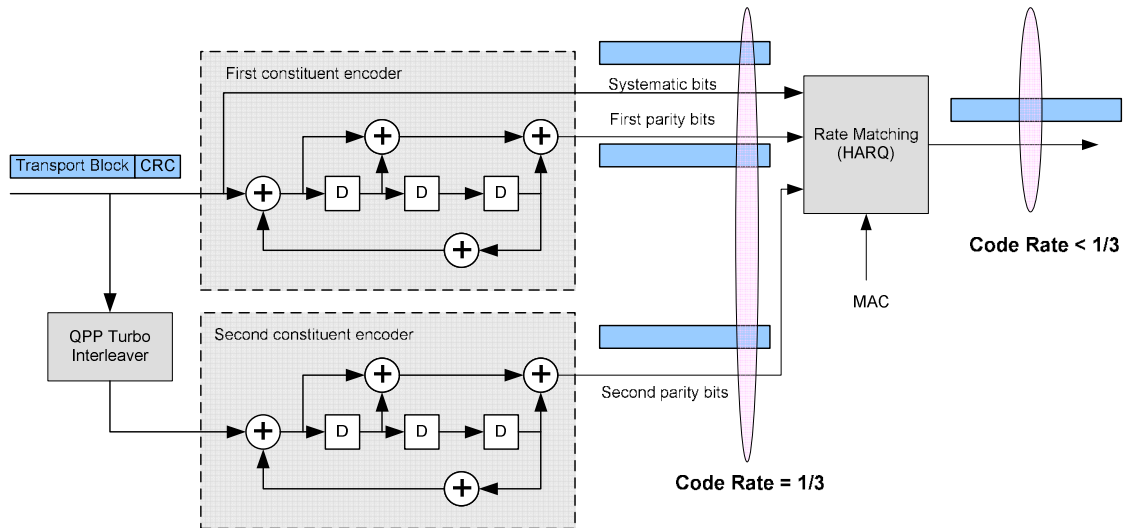

Figure 8: Overview Turbo Coding processing chain

Hybrid ARQ

- *Downlink Hybrid ARQ* retransmissions are asynchronous in time (associated HARQ signaling will be needed!). Full scheduling freedom in the downlink, but higher signaling overhead

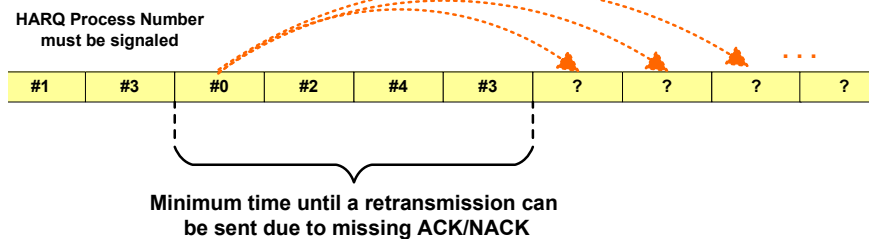

Figure 9: Downlink Asynchronous Hybrid ARQ

- *Uplink Hybrid ARQ* retransmissions are synchronous in time

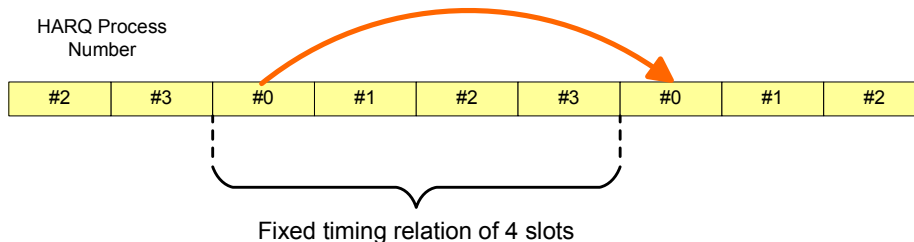

Figure 10: Uplink Synchronous Hybrid ARQ

Nomor 3GPP Newsletter – June 2007

Overview LTE PHY: Part 1 – Principles and numerology etc

Authors: Eiko Seidel

- HARQ processes are served in sequence and retransmission is sent exactly N slots after last transmission \perp No need to signal process number or redundancy version
- For up- and downlink retransmissions are adaptive with regard to resource location and transport format. This reduced the packing problem for the scheduler and allows optimum resource usage.

Interleaving

- Interleaving is still subject to standardization

Modulation

- A resource element (symbol per subcarrier) can be modulated by QPSK (2 bit per symbol) , 16QAM (4 bit per symbol) or 64QAM (8 bit per symbol) modulation

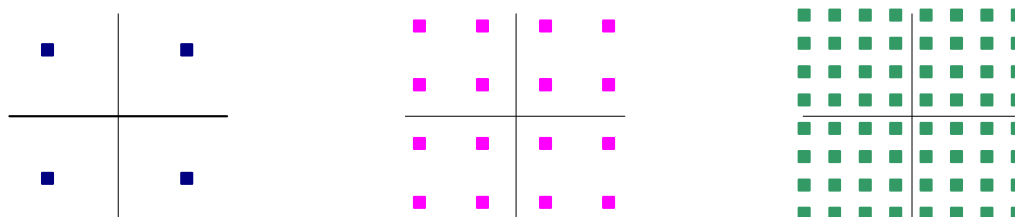

Figure 11: Supported Modulation for Shared Channel

- BPSK is used for some control channel

Scheduling and Link Adaptation

- Same coding and modulation scheme will be used for the resource allocation (all resource blocks) within a slot. Except for special multiplexing with adaptation is done per antenna.
- In general the similar principles as in HSDPA are used with CQI reporting in the uplink. CQI reporting in the UL can cover different subbands and will be configurable.
- The decision about the uplink transport format will also be done by the eNodeB and will be signaled to the UE
- Frequency selective scheduling is supported in up- and downlink. The scheduler can prefer to allocate resource on frequency blocks that have a good channel state.

Nomor 3GPP Newsletter – June 2007

Overview LTE PHY: Part 1 – Principles and numerology etc

Authors: Eiko Seidel

LTE Transmission Schemes

Downlink Transmission Scheme

- Conventional OFDM with Cyclic Prefix (CP)

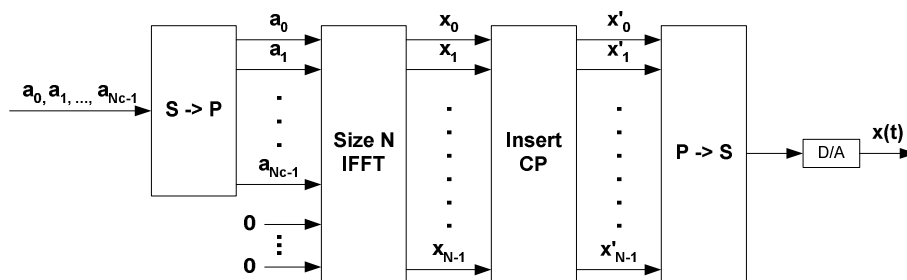

Figure 12: OFDM Modulator

- Transmitter and receiver are not mandated by spec (IFFT vs DFFT, FFT sizes, sampling rate etc.)
- $N = 2^m$ (e.g. 128, 256, 1024, 2048 etc) and $N/N_c =$ „oversampling“ ratio
- block of a N_c modulation symbols de-multiplexed from serial to parallel (data rate reduces by N_c)
- Block extended to N symbols by adding zeros before Inverse FFT
- N_{cp} samples added for Cyclic Prefix generation
- Example: LTE 10Mhz, $N_c=600$, $N=1024$

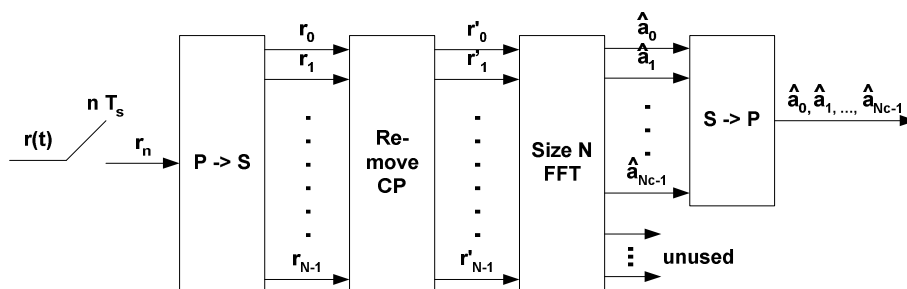

Figure 13: OFDM Demodulation

- Inverse process of the modulation process
- $f_s = N \cdot \Delta f = 1/T_s$ is the sampling rate

Nomor 3GPP Newsletter – June 2007

Overview LTE PHY: Part 1 – Principles and numerology etc

Authors: Eiko Seidel

Uplink Transmission Scheme

- OFDM numerology basically the same as in downlink
- Single Carrier – Frequency Division Multiple Access (SC-FDMA). Can be seen as a “Kind of OFMA with only adjacent Subcarriers allocated”
- Only adjacent Resource Blocks can be assigned. This complicated the scheduler due to a packing problem (remember uplink uses synchronous retransmissions as well)
- Main motivation to reduce Peak to Average Power Ratio

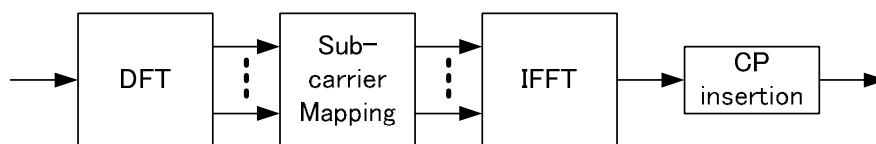

Figure 14: Uplink SC-FDMA Modulator

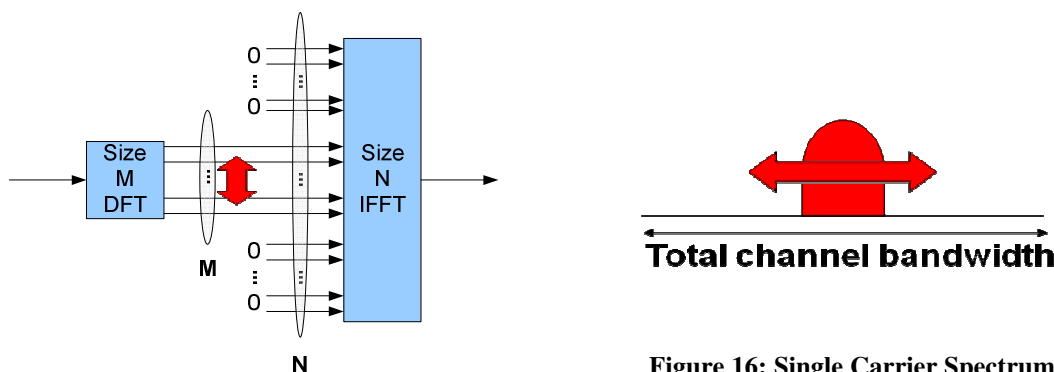

Figure 15: DFT Pre-distortion

Figure 16: Single Carrier Spectrum

- Adaptive bandwidth control (size of the carrier) by varying DFT size M
- Frequency domain scheduling (position of the subcarrier) by varying the position of M within N
- Adaptation per slot possible, thus easy realization of frequency hopping for frequency diversity and interference averaging
- Fast link adaptation and jumping between subcarrier makes link adaptation and interference prediction in the neighbor cells difficult
- During uplink data transmission channel information on that subcarrier is available by the reception of reference signals (pilots)
- More difficult as the estimation if there is no uplink transmission or in the remaining band. Additional reference symbols are defined called sounding reference symbols (SRS)

Nomor 3GPP Newsletter – June 2007

Overview LTE PHY: Part 1 – Principles and numerology etc

Authors: Eiko Seidel

LTE Up Conversion

- Up conversion of complex OFDM signal for each antenna in up- and downlink

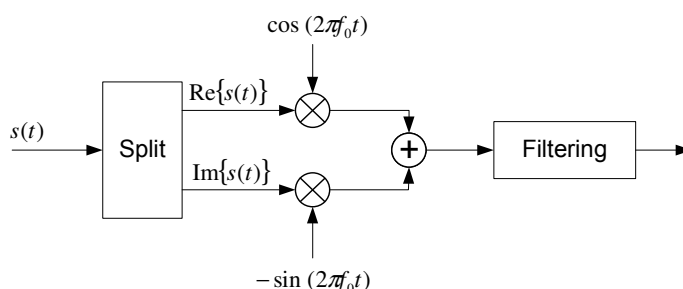

Figure 17: Up-conversion principles

- Filtering is still subject of standardization in RAN4
- Down conversion uses the inverse structure

The next newsletter ...

We will continue on the LTE PHY Overview:

- Details of Transport and Physical channels
- Layer 1/2 Control Signalling
- Physical Layer Signal (Synchronization, Reference Signals etc)

Nomor Research GmbH

Tel.: +49 (0)89 97898 000

Fax: +49 (0)89 97898 010

Email: standard@nomor.de

Web: www.nomor.de

Disclaimer: This information, partly obtained from official 3GPP meeting reports, is assumed to be reliable, but do not necessarily reflect the view of Nomor Research GmbH. The report is provided for informational purpose only. We do not accept any responsibility for the content of this newsletter. Nomor Research GmbH has no obligation to update, modify or amend or to otherwise notify the reader thereof in the event that any matter stated herein, or any opinion, projection, forecast or estimate set forth herein, changes or subsequently becomes inaccurate.